

# Civic series

C-Type High Speed Precision Press

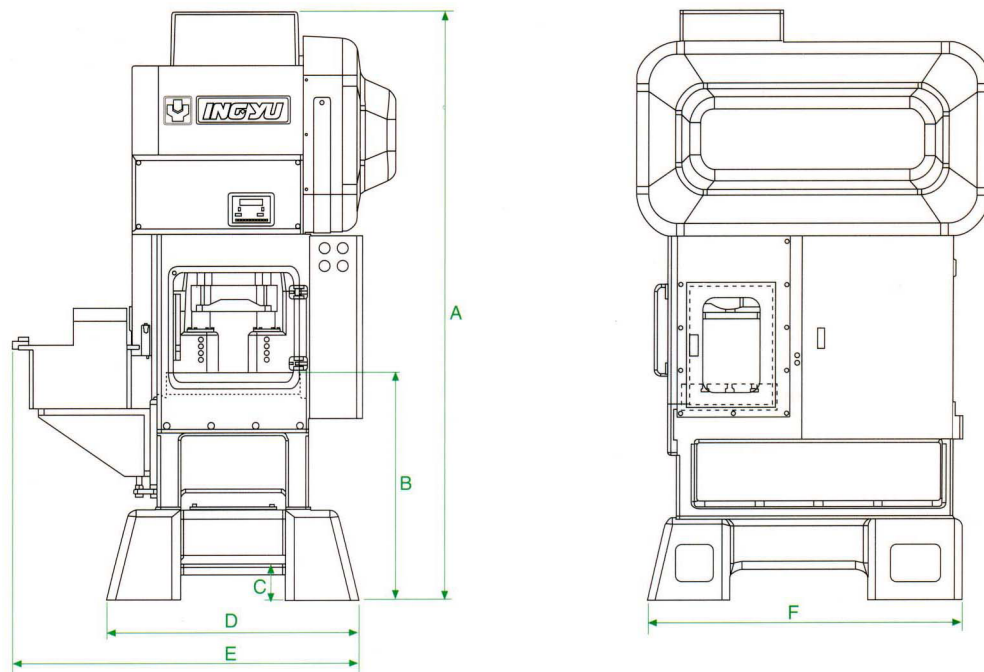



Machine Specification																	
Type		Civic-15				Civic-25				Civic-35				Civic-45			
Capacity	tons	15				25				35				45			
Slide Stroke	mm	20	25	30	40	20	25	30	40	20	25	30	40	20	25	30	40
Press Stroke	sqm	200   1200	200   1100	200   1000	200   800	200   1200	200   1100	200   1000	200   800	200   1200	200   1100	200   1000	200   800	200   1000	200   900	200   800	200   700
Shutheight	mm	210	205	205	200	210	205	205	200	265	260	260	255	265	260	260	255
Area of Bolster	mm	4500 x 300				500 x 300				600 x 380				700 x 450			
Thickness of Bolster	mm	75				80				100				120			
Area of Slide	mm	250 x 180				300 x 200				350 x 250				400 x 300			
Slide Adjustment	mm	40				40				40				40			
Main Motor	hp	5				10				15				20			
Dimension of Press																	
Height of Press (A)	mm	1965				2085				2310				2510			
Height for Operation (B)	mm	765				800				850				950			
Height for Scrap out (C)	mm	120				120				120				120			
Width of Press (D)	mm	850				900				1000				1080			
Width with Feeder (E)	mm	1173				1228				1328				1413			
Depth of Press (F)	mm	1010				1100				1250				1535			
Weight of Press	tons	2				3				4				6			